

# GPS

## Covert Mount Antenna

15/04/2014 V1

### GPSSV-VAR

- Excellent performance
- Active GPS element
- Adhesive and hook & loop pad mounting options



The GPSSV range of antennas offer excellent GPS coverage in a simple compact design. Each kit comes complete with both adhesive pad mount for a secure installation in almost any location and hook and loop pads for temporary fixing. A range of terminations are available to fit your application.

### Technical Drawing

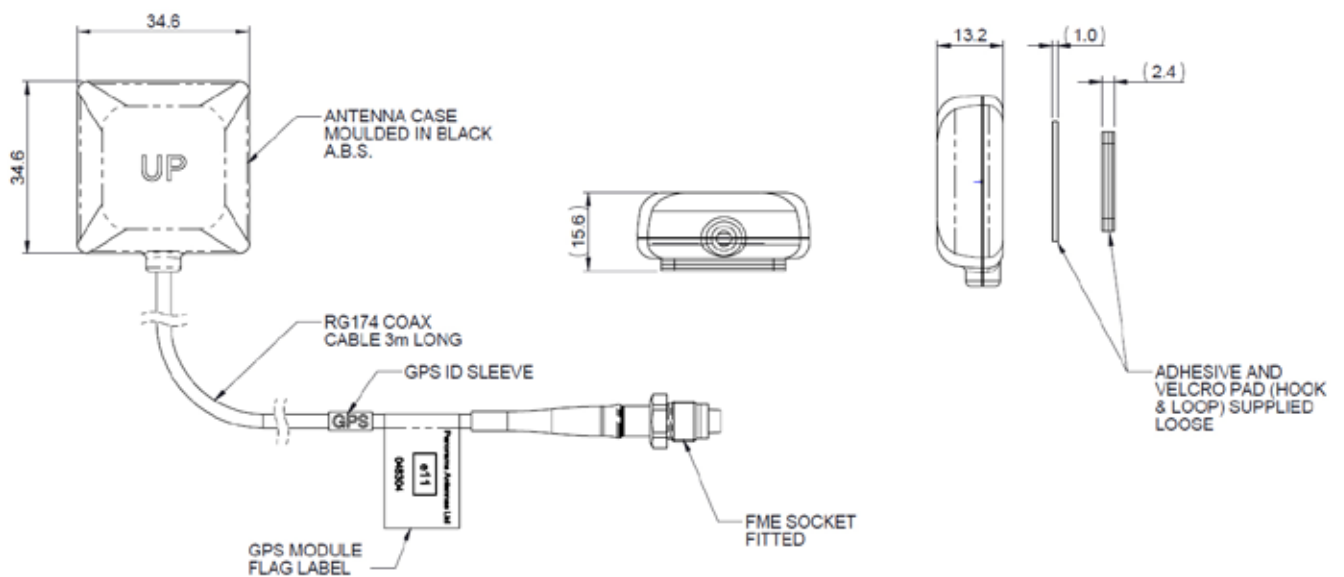

Typical E-Plane (GPS)

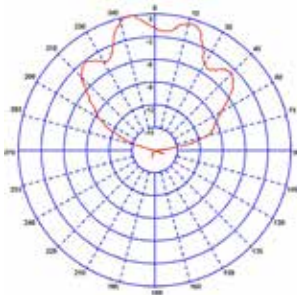

| Part No.                 | GPSSV-3F  | GPSSV-3SMCP  | GPSSV-3SMAP |
|--------------------------|---|--------------|-------------|
| <b>Electrical Data</b>   |   |              |             |
| Frequency Range (MHz)    | 1575  |              |             |
| VSWR                     | <2.0:1 @ 1575MHz ± 4MHz   |              |             |
| Gain: LNA                | 26dB  |              |             |
| Polarisation             | Right Hand Circular   |              |             |
| Operating Voltage        | 3 - 5V DC (fed via coax)  |              |             |
| Current (Typical)        | 15mA  |              |             |
| Impedance                | 50Ω   |              |             |
| GPS Approvals            | EN 301 489-1 V1.8.1 (2008-04), EN 300 440-1 V1.6.1 (2010-08), EN60950-1 |              |             |
| Automotive Type Approval | E11 - 048304  |              |             |
| <b>Mechanical Data</b>   |   |              |             |
| Dimensions (mm)          | Length  | 34.6 (1.36") |             |
|                          | Height  | 13.2 (0.5")  |             |
|                          | Width   | 34.6 (1.36") |             |
| Operating Temp (°C)      | -40°/+80°C (-40°/+176°F)  |              |             |
| Material                 | ABS   |              |             |
| Colour                   | Black   |              |             |
| <b>Mounting Data</b>     |   |              |             |
| Fixing                   | Adhesive pad/hook & loop  |              |             |
| <b>Termination Data</b>  |   |              |             |
| Type                     | RG174   |              |             |
| Diameter (mm)            | 2.5 (0.09")   |              |             |
| Length (m)               | 3 (9' 10")  |              |             |
| Termination              | FME Socket  | SMC Plug     | SMA Plug    |